

(1) Type Examination Certificate

- (2) No. of the Type Examination Certificate: **ZP/B163/19**
- (3) Product: **Edge protection system class A**
Type: Guard Trac
- (4) Manufacturer: **Tractel SAS**
- (5) Address: **Saint Hilaire sous Romilly, BP38, 10102 Romilly sur Seine Cedex, FRANCE**
- (6) The design of this product and any acceptable variation thereto are specified in the schedule to this Type Examination Certificate.
- (7) The certification body of DEKRA Testing and Certification GmbH certifies that this product complies with the fundamental requirements of the standard listed under item 8 below. The examination and test results are set out in the report PB 19-171.
- (8) The requirements of the standard are assured by compliance with
DIN EN 13374:2019
- (9) This Type Examination Certificate relates only to the design, examination and tests of the specified product in accordance to the standard list. Further requirements of the Directive apply to the manufacturing process and supply of this personal protective equipment. These are not covered by this certificate.
- (10) This Type Test Certificate is valid until 2024-07-24.

DEKRA Testing and Certification GmbH
Bochum, 2019-07-25

signed: Kilisch
Managing director

We confirm the correctness of the translation from the German original.
In the case of arbitration only the German wording shall be valid and binding.

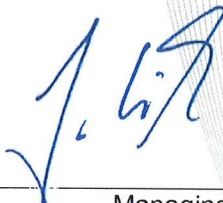
Managing director

TRANSLATION

- (11) Appendix to
- (12) **Type Examination Certificate**
ZP/B163/19
- (13) 13.1 Subject and Type
Edge protection system class A
Type: Guard Trac

13.2 Description

The edge protection system, type: Guard Trac (figure 1) is used for the collective protection of persons against falling. The installation is carried out on even substrates made of PVC foil, bituminous membrane and EPDM.

The edge protection system consists of prefabricated railing elements made of aluminum.

The railing elements are manufactured in the version with 2 posts with a length of up to 3.0 m.

The railing elements consist of \varnothing 48.3 mm tubes with a wall thickness of 3.0 mm. The railing elements have a tooth system at the foot ends, with which several railing elements can be connected via the "foot elements double". The tube ends of the railing elements are inserted for mounting in the sleeves of the foot elements. The weights which are made of concrete (25 kg individual weight) can be put on the foot elements. The weights are secured against unintentional slipping.

As additional components there is a gate as well as length adjustable railing elements. The gate can be adjusted in width from 850 mm to 1100 mm. The adjustable railing element has one safety pin which can be adjusted via a perforated grid in an adjustment range of 1500 mm to 2250 mm or from 2275 mm to 3000 mm width.

The installation of the toe board can be omitted if an attica with a minimum height of 150 mm is available. The top rail has a height of 1125 mm. The distance between the top rail and the lower rail is 437 mm. The distance between ground level and lower rail is 600 mm. At the ends of a railing system and also right next to a gate, 4 concrete weights of 25 kg each must rest on one foot element. At all other positions there must be 2 concrete weights of 25 kg each.

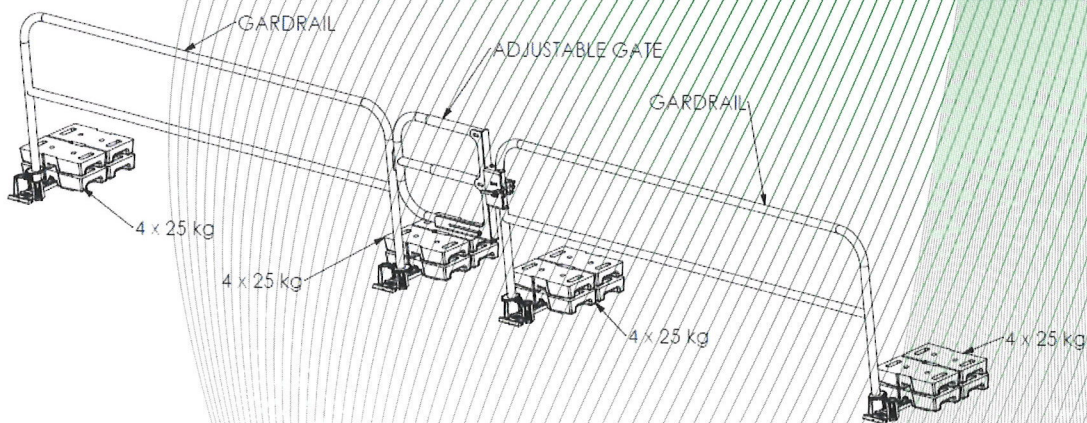

Figure 1: edge protection system type: Guard Trac

- (14) Report

PB 19-171 dd. 2019-07-15